

# NELSON™ HEAT TRACING SYSTEMS

## Z1-PLT-LPM-M25/-75NPT POWER CONNECTION KIT

### WITHOUT ENCLOSURE

## INSTALLATION INSTRUCTIONS

### DESCRIPTION

The Z1-PLT-LPM Power Connection Kit is designed for terminating one heater cable to customer supplied power wiring. This kit is designed for use with all wattages of Nelson Heat Tracing Systems' LT-J, LT-JT & HLT-J heater cables. The Z1-PLT-LPM-M25 provides compatibility to M25 metric thread standard and the Z1-PLT-LPM-75NPT provides compatibility to 0.75" NPT thread standard.

### KIT CONTENTS

- |                    |   |
|--------------------|---|
| 1 Stand-off        | 1 Power End Termination, 101.6mm (4.0")                 |
| 1 Box Adapter      | 1 G/Y Tubing, 9.5mm (0.38") diameter, 152mm (6") length |
| 1 Locknut          | 1 End Seal  |
| 1 Gasket           |   |
| 1 Sealing Grommet  |   |
| 1 Tube of Silicone |   |

*Customer supplied EEx e II Certified enclosures with a minimum ingress rating of IP54 must be used with this kit. Customer supplied EEx e II Certified terminal blocks must be used with this kit.*

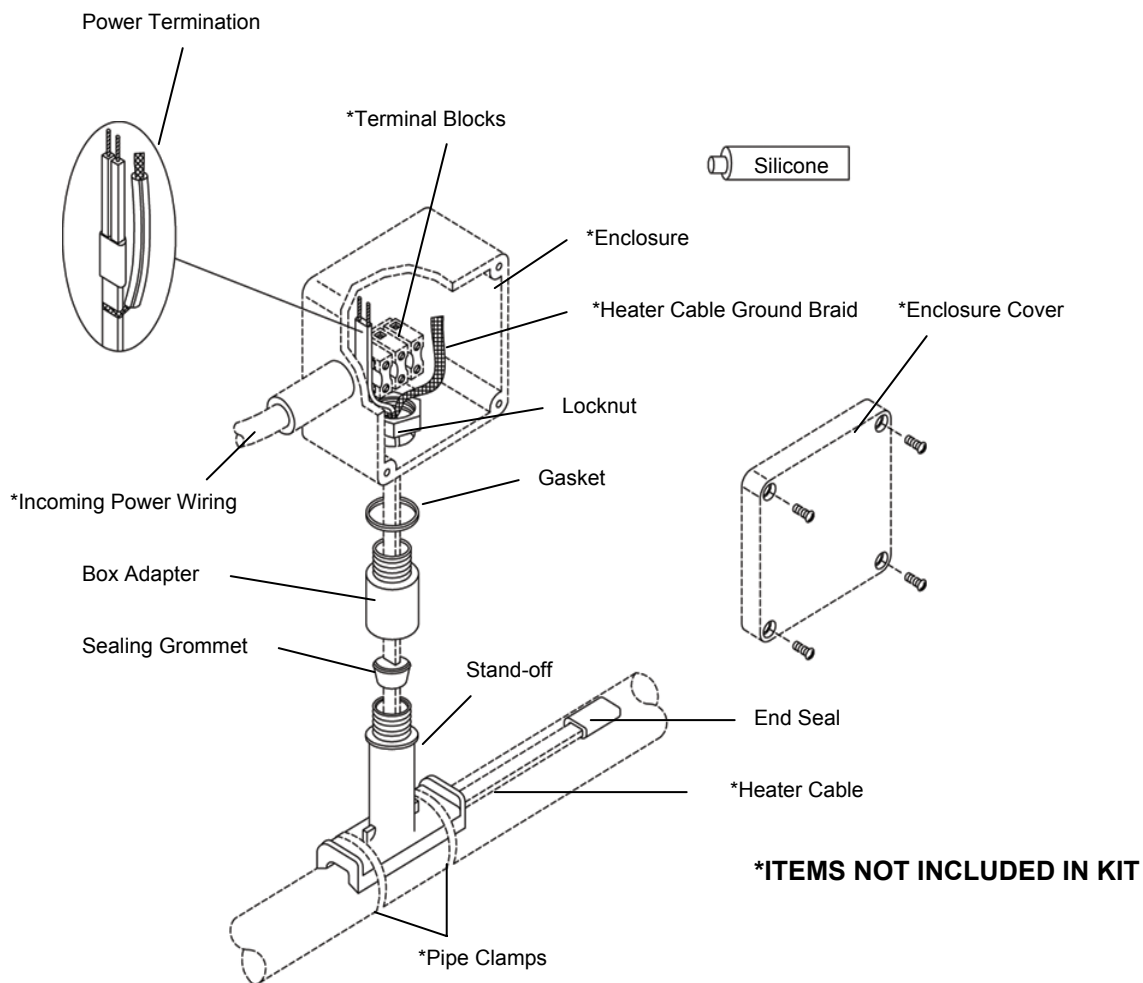

**\*ITEMS NOT INCLUDED IN KIT**

### **⚠ WARNING:**

If nuisance tripping of ground fault breakers occurs due to condensation in the enclosure, electrical connections should be moisture proofed by use of a coating or sealant.

# NELSON™ HEAT TRACING SYSTEMS

## Z1-PLT-LPM-M25/-75NPT POWER CONNECTION KIT

### WITHOUT ENCLOSURE

## INSTALLATION INSTRUCTIONS

### STAND-OFF POSITIONING

#### Section View A A

(recommend installing at the  
4 or 8 o'clock positions)

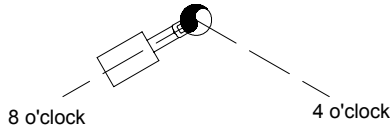

**WARNING:**  
Do not place pipe clamps  
over heater cable.

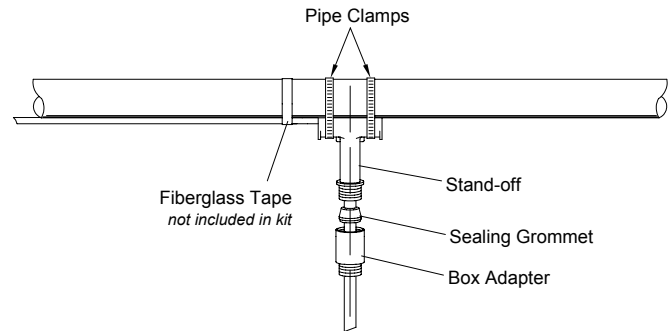
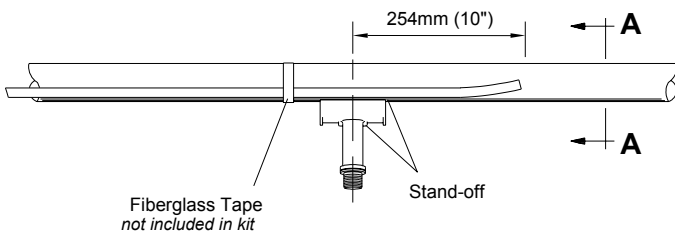

- 1) Mark pipe where stand-off will be mounted. See diagram above.
- 2) Push heater cable through the bottom opening of stand-off.
- 3) Place stand-off on the pipe and fasten with pipe clamps.
- 4) Slide the sealing grommet over the heater cable and position inside stand-off opening.
- 5) Apply silicone around the heater cable on top of the sealing grommet and fill any voids in sealing grommet.
- 6) Slide the box adapter over the heater cable and tighten securely to stand-off.
- 7) Apply silicone around the locknut and threads of the box adapter to secure the assembly.
- 8) Prepare heater cable for power termination. Proceed to sheet 3.

# NELSON™ HEAT TRACING SYSTEMS

## Z1-PLT-LPM-M25/-75NPT POWER CONNECTION KIT

### WITHOUT ENCLOSURE

## INSTALLATION INSTRUCTIONS

### HEATING CABLE PREPARATION FOR NELSON LT-J, LT-JT & HLT-J PRODUCTS

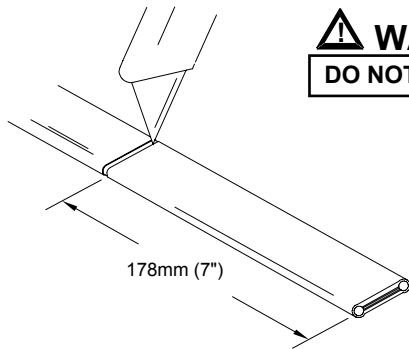

**WARNING:**  
DO NOT CUT BRAID

- 1) Lightly cut around heater overjacket 178mm (7") from the end. Bend cable to break the overjacket.
- 2) Lightly cut overjacket up the center between first cut mark and the cable end. Bend cable to break the overjacket.

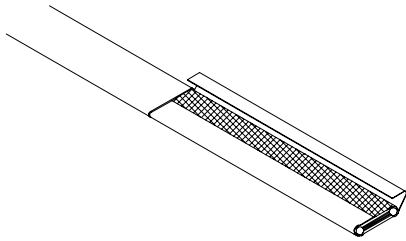

- 3) Remove overjacket from heater cable.

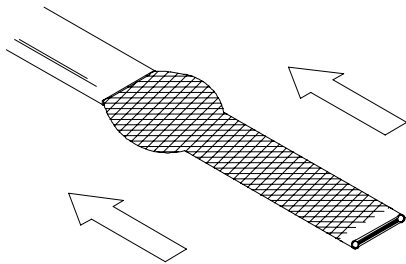

- 4) Move braid back toward the overjacket, creating a bulge.

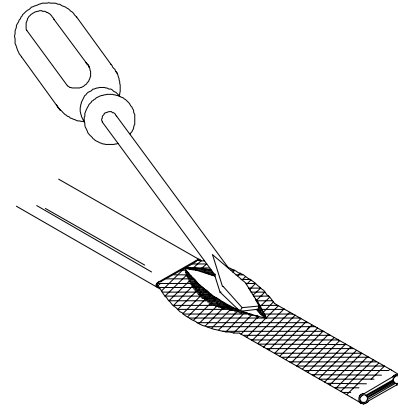

- 5) At the bulge, separate the braid to make an opening.

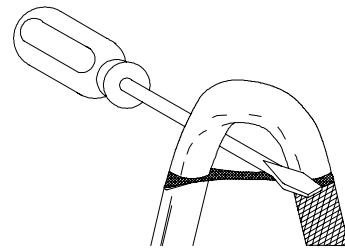

- 6) While bending the heater cable, work it through the braid opening.

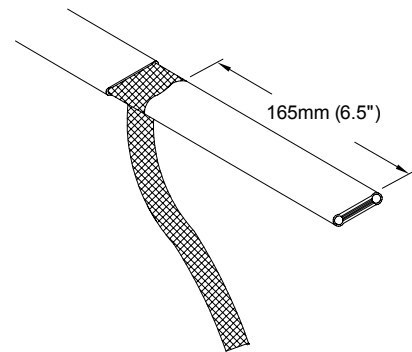

- 7) Pull the braid tight.
- 8) Proceed to sheet 4.

# NELSON™ HEAT TRACING SYSTEMS

## Z1-PLT-LPM-M25/-75NPT POWER CONNECTION KIT

### WITHOUT ENCLOSURE

## INSTALLATION INSTRUCTIONS

### HEATING CABLE PREPARATION FOR NELSON LT-J, LT-JT & HLT-J PRODUCTS

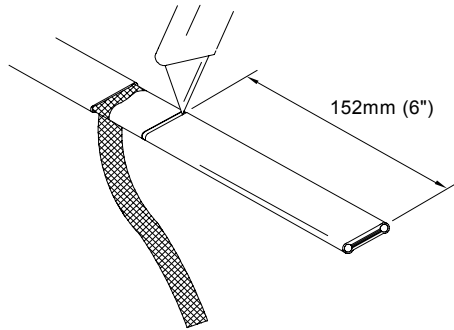

- 1) Lightly cut around cable outer jacket 152mm (6") from the end. Bend cable to break the outer jacket.
- 2) Lightly cut the outer jacket up the center between the first cut mark & the cable end. Bend cable to break the outer jacket.

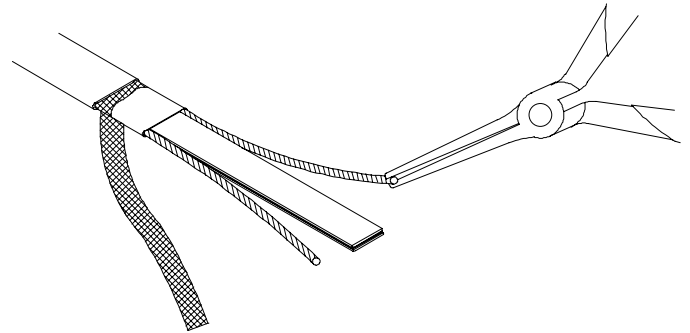

- 5) Starting at the end, pull each bus wire away from the core material.
- 6) Remove exposed core material.

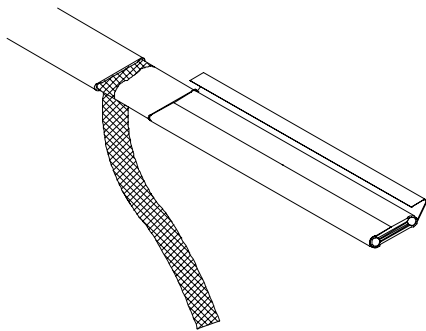

- 3) Remove the jacket from the heater cable.

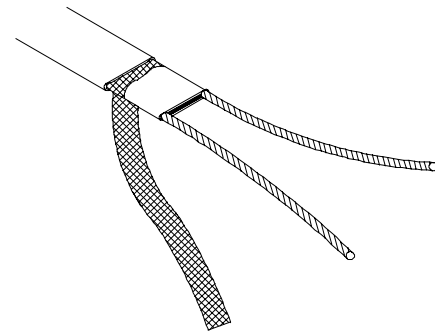

- 7) Cut 6mm (0.25") off the end of each bus wire.
- 8) Proceed to sheet 5.

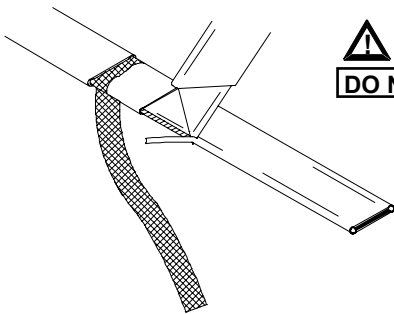

**⚠ WARNING:**  
**DO NOT CUT BUS WIRES**

- 4) Shave the core material from the outside of each bus wire.

# NELSON™ HEAT TRACING SYSTEMS

## Z1-PLT-LPM-M25/-75NPT POWER CONNECTION KIT

### WITHOUT ENCLOSURE

## INSTALLATION INSTRUCTIONS

### POWER TERMINATION FOR NELSON LT-J, LT-JT & HLT-J PRODUCTS

#### **⚠ WARNING:**

- Bus wires must not touch or cross while inserting into power termination.
- Only power terminations / end seals specifically approved for the vendors' style and type of heater cable must be used.

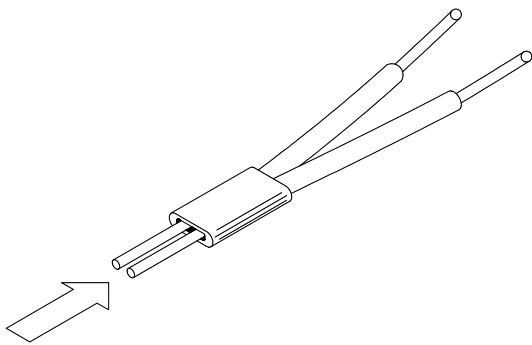

1) Insert guide tubes into power termination fitting.

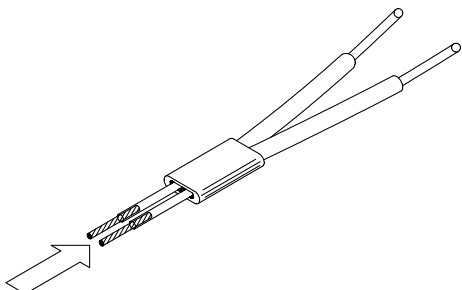

2) Insert bus wires into guide tubes.

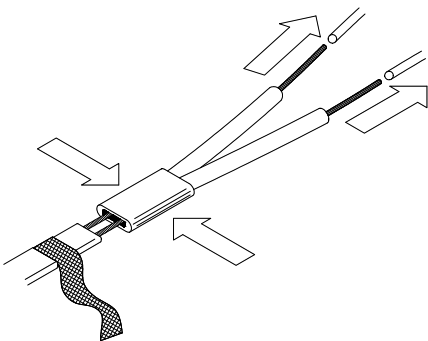

3) Remove guide tubes.  
4) Squeeze power termination opening and fill with silicone.

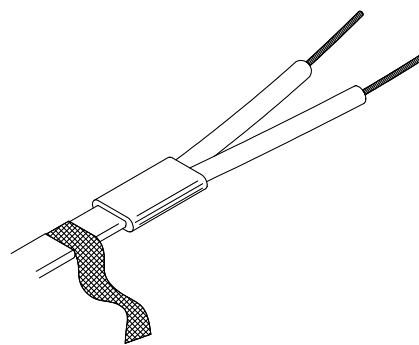

5) Push power termination to overlap jacket.  
6) The silicone will set up in about 30 minutes with a complete cure after 24 hours.

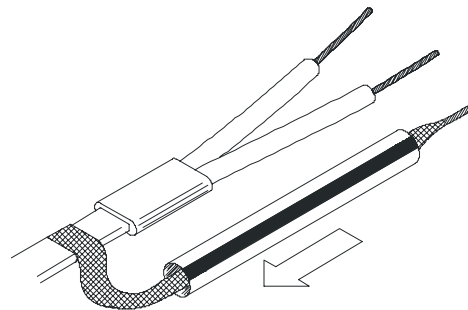

7) Slide green/yellow tubing over ground braid before terminating heater to customer supplied terminals.

#### **⚠ WARNING:**

- Do not megger or hi-pot until silicone is completely cured.
- Braid must be kept away from bus wires or shorting will occur.

# NELSON™ HEAT TRACING SYSTEMS

## Z1-PLT-LPM-M25/-75NPT POWER CONNECTION KIT

### WITHOUT ENCLOSURE

## INSTALLATION INSTRUCTIONS

### END SEAL INSTALLATION FOR NELSON LT-J, LT-JT & HLT-J PRODUCTS

#### **⚠ WARNING:**

Only end seals specifically approved for the vendor's style and type of heater cable must be used.

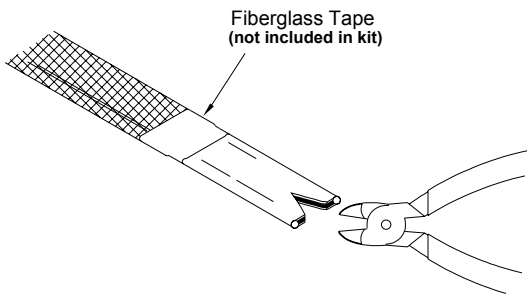

- 1) Remove 13mm (0.5") of overjacket exposing the braid then remove the 13mm (0.5") of exposed braid.
- 2) Make a 10mm (0.4") cut at the end of the heater cable.

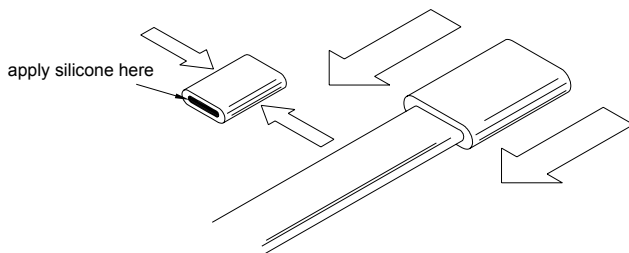

- 3) Squeeze the end seal and fill with silicone.
- 4) Push end seal over the heater cable. The end seal should overlap the overjacket.
- 5) The silicone will set up in about 30 minutes with a complete cure after 24 hours.

#### **⚠ WARNING:**

- Do not megger or hi-pot until silicone is completely cured.
- Braid must be kept away from bus wires or shorting will occur.

# NELSON™ HEAT TRACING SYSTEMS

## Z1-PLT-LPM-M25/-75NPT POWER CONNECTION KIT

### WITHOUT ENCLOSURE

## INSTALLATION INSTRUCTIONS

### POWER CONNECTION FOR NELSON LT-J, LT-JT & HLT-J PRODUCTS

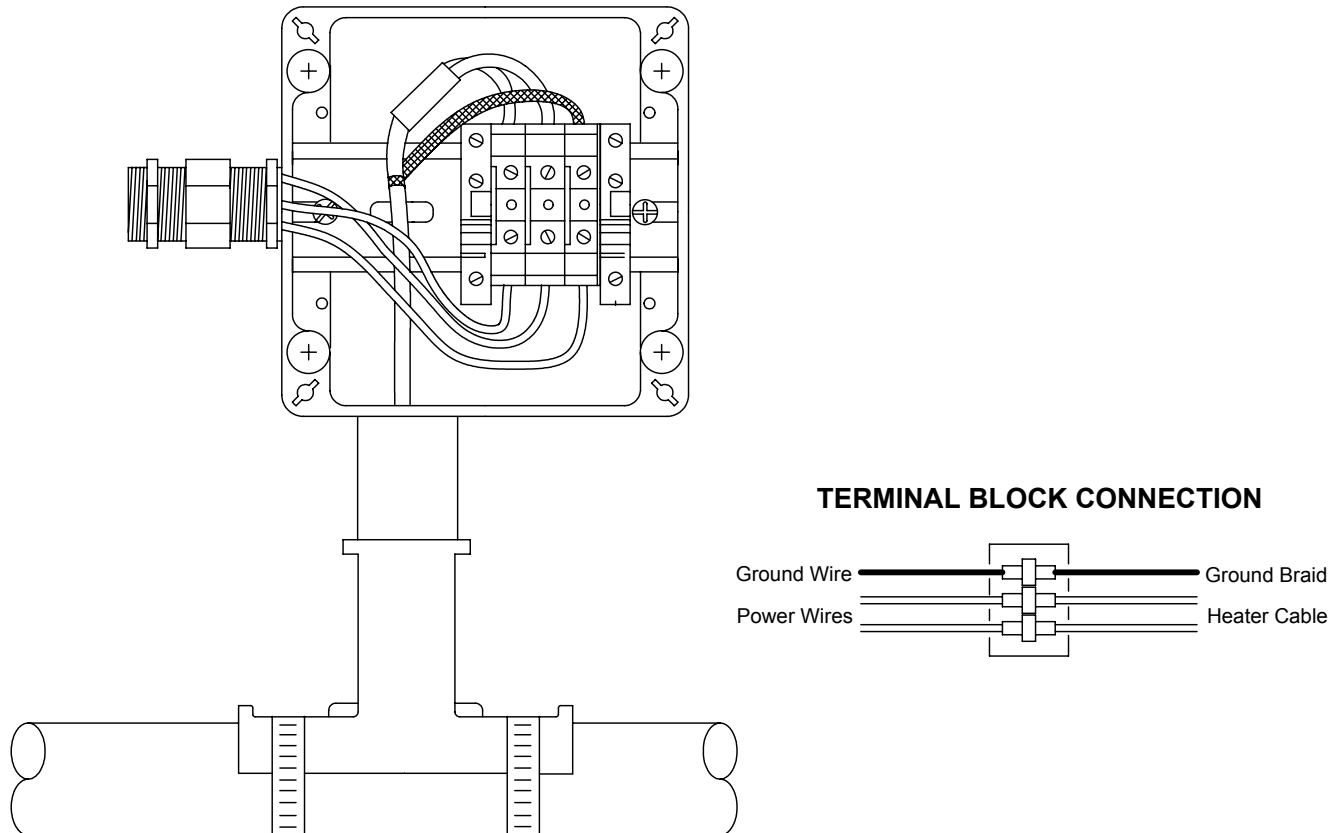

- 1) Place gasket on box adapter.
- 2) Position enclosure on box adapter and apply silicone around the locknut before securing.
- 3) Connect the bus wires, power wires, ground wire and ground braid to the terminal block. See diagram above.
- 4) Push all wires and terminal block inside the enclosure.
- 5) Place the cover onto the enclosure.

Nelson Heat Tracing Systems products are supplied with a limited warranty. Complete Terms and Conditions may be found on Nelson's website at [www.nelsonheaters.com](http://www.nelsonheaters.com).